

**VOLVO COMPACT EXCAVATORS**  
**EC25, EC30**



**MORE CARE. BUILT IN.**



# DEMANDING PERFORMANCE - ON DEMAND.

The jobs are getting more demanding and the Volvo EC25 and EC35 Compact Excavators are ready. Experience smooth control, comfort and versatility. With ease of service, durability, and safety throughout, you get the ultimate in productivity and profitability for your tough demands.

## Your top performer

We always look to the best and keep going back, because we know the best always delivers. Look to the Volvo EC25 and EC30, and meet your new top performer. Climb in the spacious cab, look around and get a visual command of the entire jobsite with excellent visibility and clear line of sight down to the bucket. Dig in with the powerful Volvo bucket and get the performance you demand with a large range of movement that rotates over 200°. It's the type of bucket performance you would expect from a full-size excavator and it guarantees a good entry angle and square excavations at all depths. And because many of today's jobsites are narrow and congested, you'll appreciate the hydraulic offset of the boom, which reduces the overall dimensions of the excavator and makes it possible to work alongside a wall, building or roadside.

## An efficient use of your resources

Get the job done and save some of your valuable resources - like time and fuel. The new generation Volvo engine offers proven performance, superior fuel efficiency and power for fast cycle times that will get you moving on to the next profitable job. With strong bucket breakout and digging depth deep enough to get the job done, the EC25 and EC30 are the perfect fit for the job. The powerful load-sensing hydraulic system uses the best technology available. And it's not only easy to operate, it also gives you powerful, smooth operation and a total independence of all movements. The hydraulic load-sensing circuit enables the use of two or more hydraulic functions without loss of power or movement. Get ready for increased productivity, because it's never been easier to get more done.

## Make quick work of multiple jobs

With compact equipment, you want the flexibility to tackle a wide range of jobs with speed and ease for maximum profits. Volvo EC25 and EC30 Compact Excavators help you do more with the exclusive Volvo quick coupling attachment bracket. Move from job to job, switching buckets and attachments with ease - all from the operator's cab. The next time the job calls for a variety of tasks, you won't need an entire fleet of machines. The Volvo quick coupling attachment bracket gets the job done fast.

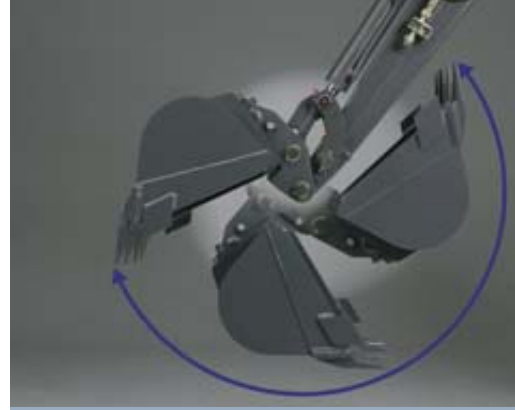

- Large range of movement: over 200°.



- Wide range of available attachments.



- Quick coupler for fast, easy changes.



- Rear impact protected counterweight.
- Optimum load-sensing efficiency.
- Easy to use, smooth precise controls.



# THE COMFORTABLE SIDE OF DURABILITY.

On the jobsite, there's a lot going on. In a Volvo EC25 or EC30, you're in total control, with your attention keenly focused on the task. You're surrounded in comfortable features and quality, sturdy components built to last. The day is long, but you are ready - just like your machine.

## Comfort that brings out your best

Open the cab door and experience the spacious Volvo cab. The vast, flat floor provides plenty of legroom, even for tall operators. There's also ample space for tools and personal items. The transport levers are equipped with pedals for simultaneous control of the earthmoving equipment and of forward movement. The hydraulic attachment control pedal is positioned to the right for easy access, folding away when not in use.

## It's all right here

Inside, everything you need is perfectly placed - right in front of you - in sight and at easy reach. The instrument panel with grouped control gauges keeps you informed of all key machine functions. The power-assisted controls offer the quick and smooth, precise operation you demand - particularly when performing delicate, detail work. With ergonomically designed armrests, the forearms rest comfortably to keep you refreshed and more productive. The short responsive manipulators avoid excessive operating movements, reduce fatigue and offer precise control.

## Built for big performance

The design is compact, but the performance is bigger than you might expect. Just like larger Volvo Excavators, the Volvo EC25 and EC30 Compact Excavators are built to last, with durable frames and components. The direct swing gear is driven directly by a hydraulic motor. The direct motor drive eliminates the intermediate carrier commonly used on compact excavators. There is no wear, play or maintenance cost related to a carrier driven machine. The long-length durable tracks offer exceptional stability, greater safety and reduced ground pressure.

## Built for today's jobsites

Durability means long life and greater uptime. The sturdy top frame features a twin-yoke boom swing pivot that doubles the wear surface area in the frame. This allows for a longer pin to be utilized. This provides a better distribution of stress, with less wear and reduced pin to bearing play. The X-shaped undercarriage offers a better load distribution on the side members for more rigidity and sturdiness. The top part of the side members slope to prevent debris collection and to facilitate easy cleaning. And for safe operation on today's narrow jobsites, the wrap-around shape of the counterweight provides excellent protection against rear impacts.

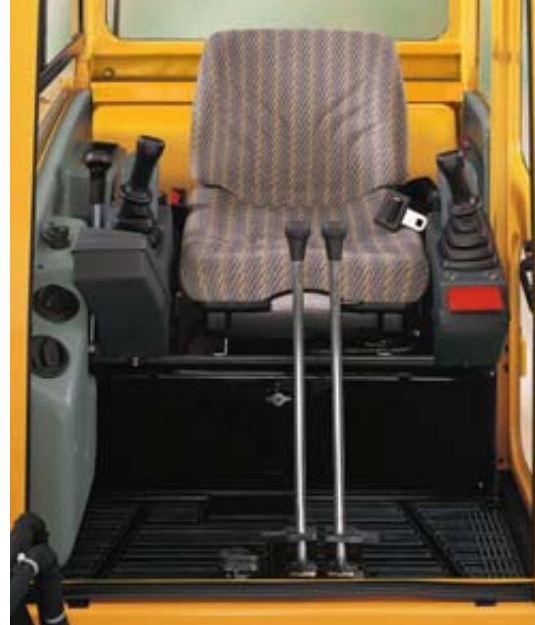

- Spacious and comfortable cab.



- All-day comfort ergonomic armrests.



- Large floor area and plenty of legroom.



- Instrument panel keeps you informed.
- No wear, no play swing = no maintenance.
- The long length durable tracks offer exceptional durability.



# SAFELY MAINTAIN YOUR PRODUCTIVITY.

At Volvo, your safety is our priority. That's why Volvo EC25 and EC30 Compact Excavators are built with safety features that keep you working with complete peace of mind. To keep you productive - longer - Volvo Compact Excavators are built for ease of service and maximum uptime.

## You're in the safe zone

It's time to get to work, and Volvo makes sure it's safe from the first step. Climb into the operator's cab, gripping the safety handles and entering through the wide opening door. The cab floor and steps are non-slip. When the left console is raised, all machine travel controls are locked in the neutral position to avoid risk of accident. Seated in the quiet cab, experience excellent 360° visibility thanks to large window surface areas that provide a superior command of the entire jobsite. The rounded contour and very compact shape of the engine cover also provides good visibility to the rear, particularly on congested jobsites.

## Protecting what's important

Today's jobsites can be dangerous and unpredictable. That's why Volvo helps to ensure operator safety with durable structures. The EC25 and EC30 feature cabs and canopies of a very high level of safety, guaranteed by the FOPS 1, ROPS and TOPS certifications. And to keep you safely planted in your seat, a seatbelt is standard equipment.

## All access availability

The best way to achieve greater productivity and greater profitability is through dependable machines that are up and running. Volvo helps you avoid unplanned downtime with machines built for simple, easy maintenance. The key is accessibility, and the EC25 and EC30 provide perfect accessibility to the hydraulics and engine compartments. The control valves and all of the hydraulic components are located in an easy access hydraulics compartment located on the side of the machine. And for the ultimate in engine access, you'll appreciate a Volvo exclusive: the opening counterweight. This Volvo innovation not only offers excellent accessibility of the engine compartment, it also provides total protection to the rear of the machine, due to the wrap-around shape of the counterweight.

## Intelligent, by design

For less wear and less maintenance time, all of the hoses that supply the boom are loose fitted on the outside of the machine, without going into the pivot. This helps prevent rubbing and wear, while making it easy to replace the hoses if necessary. It's just another of the many ways Volvo offers More care. Built in.

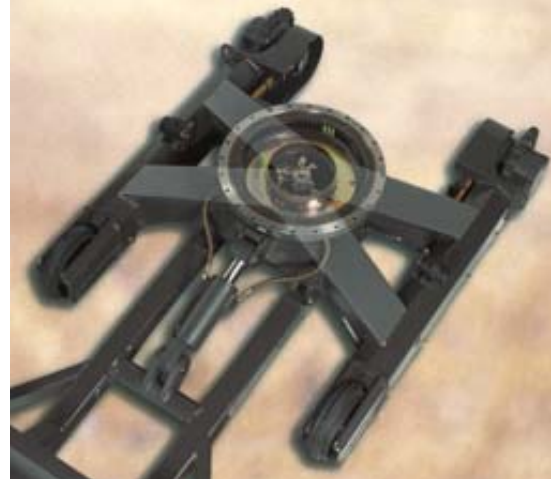

- Sturdy, rigid X-shaped chassis.



- Locking controls help prevent accidents.



- Complete hydraulic compartment access.



- Loose fitting hoses resist downtime.
- Long-life sturdy top chassis.
- Swinging counterweight for easy access.



# SPECIFICATIONS - EC25/30

## Engine

Water-cooled, low-emission, Mitsubishi 3-cylinder diesel engine in conformity with US EPA regulation.

<b>Model</b>	<b>S3L2</b>
<b>Gross power, rated</b>	<b>26.8 hp (20 kW) @ 2,800 rpm (46.7 rps)</b>
<b>Power, installed (ISO 9249)</b>	
<b>EC25</b>	<b>22.9 hp (17.1 kW) @ 2,200 rpm (36.7 rps)</b>
<b>EC30</b>	<b>23.8 hp (17.8 kW) @ 2,400 rpm (40 rps)</b>
<b>Displacement, total</b>	<b>80 in3 (1,318 cc)</b>
<b>Maximum torque</b>	<b>36.8 lbf/ft @ 21,600 rpm (77 Nm @ 6.7 rps)</b>
<b>Bore x stroke</b>	<b>3.1 in x 3.6 in (78 mm x 92 mm)</b>

## Electrical system

<b>Rated voltage</b>	12 V
<b>Battery capacity</b>	12 V - 70 Ah
<b>Alternator rating</b>	12 V - 50 A
<b>Starter motor output</b>	<b>2.7 hp (2kW)</b>

## Hydraulic system

Closed-center, load-sensing hydraulic system providing independence of each function. Control power-assisted hydraulic controls. Variable displacement load-sensing pump for all the equipment and travel circuits:

<b>Maximum flow</b>	<b>16.4 US gpm (62 l/min)</b>
<b>Maximum operating pressure</b>	
<b>EC25</b>	<b>3,335 PSI (230 bar)</b>
<b>EC30</b>	<b>3,625 PSI (250 bar)</b>

Gear pump for the power assistance circuit:

<b>Maximum flow</b>	<b>4.65 US gpm (17.6 l/min)</b>
<b>Maximum operating pressure</b>	<b>464 PSI (32 bar)</b>

Double-acting hydraulic circuit for accessories:

<b>Maximum flow</b>	<b>11.89 US gpm (45 l/min)</b>
<b>Maximum operating pressure</b>	
<b>EC25</b>	<b>3,335 PSI (230 bar)</b>
<b>EC30</b>	<b>3,625 PSI (250 bar)</b>

End-of-stroke cushions

<b>On boom ram</b>	at the end of the rod extension
--------------------	---------------------------------

## Bucket performance

### Breakout force

<b>EC25</b>	<b>4,900 lbf (2,180 daN)</b>
<b>EC30</b>	<b>5,440 lbf (2,420 daN)</b>

### Tearout force

<b>EC25</b>	<b>3,350 lbf (1,490 daN)</b>
<b>EC30</b>	<b>3,867 lbf (1,720 daN)</b>

## Swing system

Turntable swing is provided by a radial piston hydraulic motor (without a reduction gear) and a ball internal crown wheel with remote lubrication:

<b>Swing speed</b>	10 rpm
<b>Turntable braking</b>	automatic multi-disc brake
<b>Absorption of hydraulic shocks</b>	Hydrosensor shockless valve

## Undercarriage

The undercarriage is made up of an "X" box fabricated center part, for more rigidity, and sloping side members for better shading of materials. The rollers and the tensioning wheels are lubricated for life.

<b>Bottom/top rollers per side</b>	3 / 1
<b>Track width</b>	<b>1'0" (300 mm)</b>
<b>Track tension</b>	by grease piston
<b>Blade (width x height)</b>	<b>5'0" x1'11" (1,530 x 340 mm)</b>

## Drivetrain

Each track is driven by an axial piston hydraulic motor equipped with two speeds and an epicyclic reduction gear.

<b>Max. speed (low speed/ high speed)</b>	<b>1.5 - 2.3 mph (2.4 - 3.7 km/h)</b>
<b>Max. tractive force</b>	
<b>EC25</b>	<b>5,687 lbf (2,530 daN)</b>
<b>EC30</b>	<b>6,182 lbf (2,750 daN)</b>

The travel circuit is automatically locked when the operator raises the left console.

## Service fill capacities

<b>Fuel tank</b>	<b>13 US gal (49 l)</b>
<b>Hydraulic tank</b>	<b>5.15 US gal (19.5 l)</b>
<b>Hydraulic system, total</b>	<b>12.29 US gal (46.5 l)</b>
<b>Engine oil</b>	<b>1.4 US gal (5.2 l)</b>
<b>Cooling system</b>	<b>1.6 US gal (6 l)</b>

## Weight

### EC25

<b>Operating mass</b>	Rubber Tracks	Steel Tracks
<b>Cab version</b>	<b>6,152 lbs (2,790 kg)</b>	<b>6,286 lbs (2,851 kg)</b>
<b>Canopy version</b>	<b>5,874 lbs (2,664 kg)</b>	<b>6,008 lbs (2,725 kg)</b>

### Ground pressure

	Rubber Tracks	Steel Tracks
<b>Cab version</b>	<b>4.3 lbs/in<sup>2</sup> (0.30 kg/cm<sup>2</sup>)</b>	<b>4.4 lbs/in<sup>2</sup> (0.31 kg/cm<sup>2</sup>)</b>
<b>Canopy version</b>	<b>4.1 lbs/in<sup>2</sup> (0.29 kg/cm<sup>2</sup>)</b>	<b>4.3 lbs/in<sup>2</sup> (0.30 kg/cm<sup>2</sup>)</b>

### EC30

<b>Operating mass</b>	Rubber Tracks	Steel Tracks
<b>Cab version</b>	<b>6,813 lbs (3,090 kg)</b>	<b>6,948 lbs (3,151 kg)</b>
<b>Canopy version</b>	<b>6,536 lbs (2,964 kg)</b>	<b>6,670 lbs (3,025 kg)</b>

### Ground pressure

	Rubber Tracks	Steel Tracks
<b>Cab version</b>	<b>4.5 lbs/in<sup>2</sup> (0.32 kg/cm<sup>2</sup>)</b>	<b>4.7 lbs/in<sup>2</sup> (0.33 kg/cm<sup>2</sup>)</b>
<b>Canopy version</b>	<b>4.4 lbs/in<sup>2</sup> (0.31 kg/cm<sup>2</sup>)</b>	<b>4.5 lbs/in<sup>2</sup> (0.32 kg/cm<sup>2</sup>)</b>

## Noise levels

Results of dynamic measurements:

<b>Noise level exterior (LwA)</b>	95 dB(A)
<b>Noise level in the cab (LpA)</b>	
<b>EC25</b>	80 dB(A)
<b>EC30</b>	82 dB(A)
<b>Noise level under the canopy (LpA)</b>	80 dB(A)



# SPECIFICATIONS - EC25

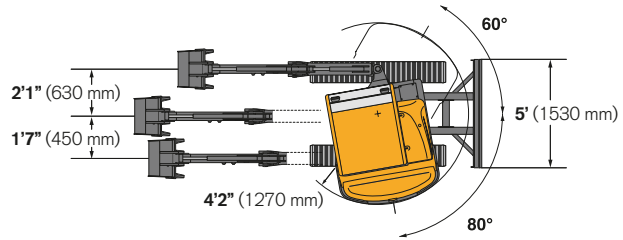
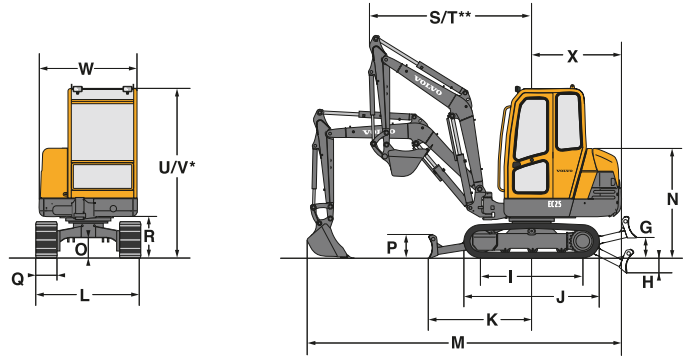
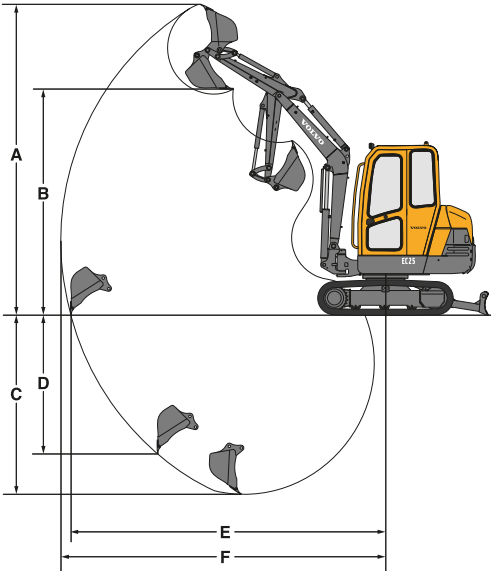

Buckets			
	Width	Weight	Capacity
Excavator	10" (250 mm)	88 lbs (40 kg)	1,13 ft <sup>3</sup> (35 l)
	12" (300 mm)	101 lbs (46 kg)	1,31 ft <sup>3</sup> (37 l)
	16" (400 mm)	121 lbs (55 kg)	1,94 ft <sup>3</sup> (55 l)
	18" (450 mm)	132 lbs (60 kg)	2,3 ft <sup>3</sup> (65 l)
	20" (500 mm)	145 lbs (66 kg)	2,58 ft <sup>3</sup> (73 l)
	24" (600 mm)	165 lbs (75 kg)	3,21 ft <sup>3</sup> (91 l)
Ditch	30" (750 mm)	185 lbs (84 kg)	4,2 ft <sup>3</sup> (119 l)
	51" (1,300 mm)	275 lbs (125 kg)	5,3 ft <sup>3</sup> (153 l)

Dipper	A	B	C	D	E	F
3'11" (1,200 mm)	14'2" (4,330)	10'3" (3,130)	8'3" (2,520)	6'7" (2,000)	14'8" (4,460)	15'0" (4,580)
4'11" (1,500 mm)	14'10" (4,520)	10'11" (3,320)	9'3" (2,820)	7'6" (2,290)	15'7" (4,750)	16'0" (4,870)

G	H	I	J	K	L	M	N	O
1'3" (390)	1'8" (520)	4'9" (1,440)	6'3" (1,910)	4'9" (1,450)	4'10" (1,480)	13'10" (4,220)	5'1" (1,550)	0'11" (280)

P	Q	R	S	T	U	V	W	X
1'1" (340)	1'0" (300)	1'10" (570)	6'0" (1,830)	4'8" (1,420)	7'10" (2,390)	7'9" (2,350)	4'8" (1,420)	4'2" (1,260)

Capacities listed are for a machine without a bucket or quick-release coupling and fitted with a 3'11" (1200 mm) dipper, rubber tracks and cab.

The handling capacity is 75% of the tipping load or 87% of the hydraulic limit.

Outreach	4'11" (1.50 m)	6'7" (2.00 m)	8'2" (2.50 m)	9'10" (3.00 m)	11'6" (3.50 m)	12'10" (3.90 m)
	lbs (kg)	lbs (kg)	lbs (kg)	lbs (kg)	lbs (kg)	lbs (kg)
	Z2	-	2,679* (1215*)	1,566* (710*)	1,356* (615*)	1,499* (680*)
	Z1	3,616* (1660*)	2,679* (1215*)	2,051* (930*)	1,786* (810*)	1,654* (750*)
	Z3	5,369* (2435*)	3,737* (1695*)	2,734* (1240*)	2,448* (1110*)	-
	Z2	-	2,149 (975)	1,566* (710*)	1,191 (540)	948 (430)
	Z1	3,241 (1470)	1,996 (905)	1,444 (655)	1,136 (515)	926 (420)
	Z3	3,285 (1490)	2,040 (925)	1,444 (665)	1,147 (520)	-

\* hydraulic limit



Lifting capacity in front longitudinal position and resting on the blade.



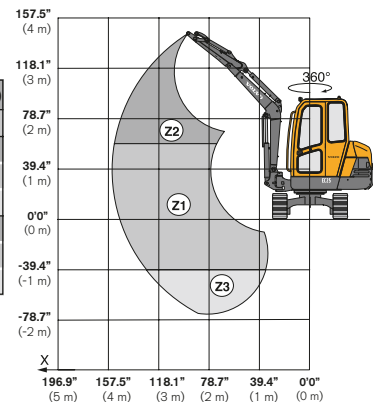

Lifting capacity in total rotation over 360° with the blade raised.

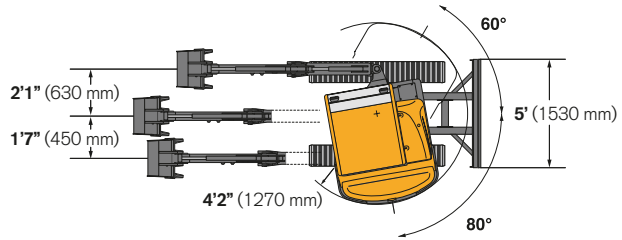
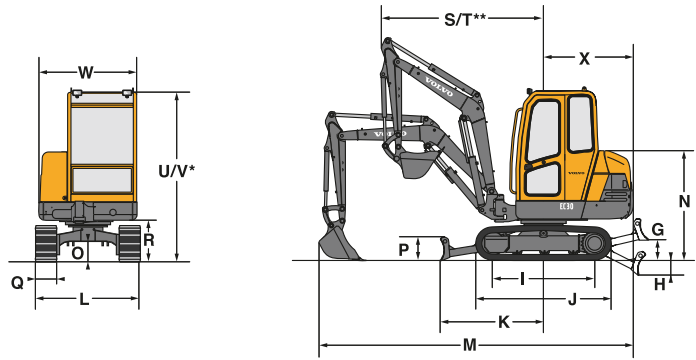
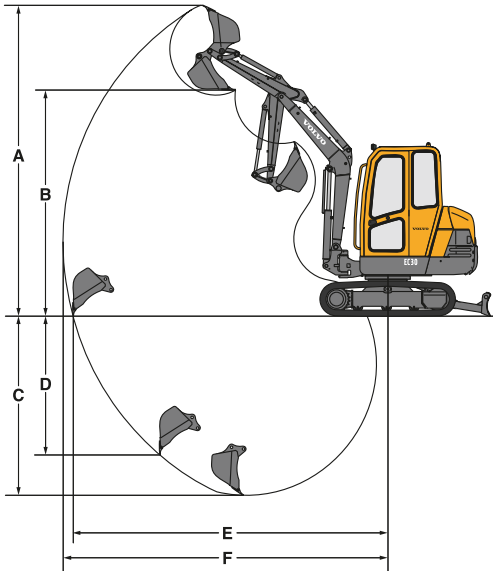

# SPECIFICATIONS - EC30



Buckets			
	Width	Weight	Capacity
Excavator	10" (250 mm)	90 lbs (41 kg)	1,13 ft <sup>3</sup> (35 l)
	12" (300 mm)	104 lbs (47 kg)	1,31 ft <sup>3</sup> (37 l)
	16" (400 mm)	126 lbs (57 kg)	1,94 ft <sup>3</sup> (55 l)
	18" (450 mm)	139 lbs (63 kg)	2,3 ft <sup>3</sup> (65 l)
	20" (500 mm)	150 lbs (68 kg)	2,58 ft <sup>3</sup> (73 l)
	24" (600 mm)	172 lbs (78 kg)	3,21 ft <sup>3</sup> (91 l)
Ditch	30" (750 mm)	194 lbs (88 kg)	4,2 ft <sup>3</sup> (119 l)
	51" (1,300 mm)	275 lbs (125 kg)	5,3 ft <sup>3</sup> (153 l)



Dipper	A	B	C	D	E	F
3'11" (1,200 mm)	14'7" (4,450)	10'8" (3,250)	9'0" (2,740)	7'1" (2,150)	15'2" (4,620)	15'7" (4,740)
4'11" (1,500 mm)	15'3" (4,640)	11'3" (3,430)	10'0" (3,040)	8'0" (2,440)	16'1" (4,910)	16'6" (5,030)

G	H	I	J	K	L	M	N	O
1'3" (390)	1'8" (520)	4'9" (1,440)	6'3" (1,910)	4'9" (1,450)	4'10" (1,480)	14'4" (4,370)	5'1" (1,550)	5'1" (1,550)

P	Q	R	S	T	U	V	V	X
1'1" (340)	1'0" (300)	1'10" (570)	6'5" (1,950)	5'0" (1,530)	7'10" (2,390)	7'8" (2,340)	7'8" (2,340)	4'2" (1,260)

These capacities are given for a machine without a bucket or quick-release coupling and fitted with a 2'11" (900 mm) dipper, rubber tracks and cab.

The handling capacity is 75% of the tipping load or 87% of the hydraulic limit.

Outreach		4'11" (1.50 m)	6'7" (2.00 m)	8'2" (2.50 m)	9'10" (3.00 m)	11'6" (3.50 m)	13'1" (4.00 m)
		lbs (kg)	lbs (kg)	lbs (kg)	lbs (kg)	lbs (kg)	lbs (kg)
	Z2	-	-	1,643 (745)	1,268 (575)	1,014 (460)	1,742* (790*)
	Z1	3,352* (1,520*)	3,815* (1,730*)	1,555 (705)	1,213 (550)	992 (450)	1,742* (790*)
	Z3	5,016* (2,275*)	2,900* (1,315*)	1,566 (710)	1,224 (555)	1,577* (715*)	-
	Z2	-	2,271 (1,030)	1,841* (835*)	1,433* (650*)	1,808* (820*)	838 (380)
	Z1	3,352 (1,520)	2,139 (970)	2,381* (1,080*)	2,007* (910*)	1,808* (820*)	838 (380)
	Z3	3,517 (1,595)	2,183 (990)	3,032* (1,375*)	2,238* (1,015*)	-	-

\* hydraulic limit



Lifting capacity in front longitudinal position and resting on the blade.



Lifting capacity in total rotation over 360° with the blade raised.

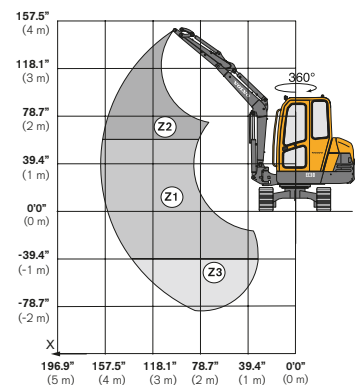

## STANDARD EQUIPMENT

### Engine

Dry-type air filter.  
Electric pre-heating device.  
Fuel water trap with sediment bowl.  
Purge plug under the diesel oil tank.  
Oil pan guard.  
Continuous adjustment of engine speed.

### Electrical system

12 V - 70 Ah battery.  
Horn.  
12 V power socket for inspection lamp.

### Undercarriage

1'10" (300 mm) wide rubber tracks.  
Dozer blade.  
Towing and anchoring points.  
Remote lubrication of the swing crown ring.

### Hydraulic system

Control pattern selector valve (ISO/SAE).  
Circuit for hydraulic breaker with folding control pedal and direct return of oil to the hydraulic tank.  
Piping as far as dipper arm.  
Power-assisted control of the hydraulic offset of the boom by the left control lever.  
Control of travel movement by two levers coupled to pedals.

### Cab

Level 1 FOPS (Falling Objects Protective Structure).  
TOPS (Tip-Over Protective Structure).  
ROPS (Roll-Over Protective Structure).  
Fabric-covered, multi-adjustable, suspended seat.  
Non-slip floor and grab handle for access to the driver's cab.

Seatbelt.  
Cab mounted on rubber mountings.  
Two working lights.  
Two-speed heating and ventilation.  
Cab heating adjustment.  
Front window with opening system power-assisted by two gas rams.  
Sliding window (right).  
Door stops.  
Provision for a radio (location for a radio and two speakers, antenna and electric wiring already fitted).  
Interior lighting.  
Anti-corrosion protection of the cab.  
Windshield wiper and washer (front).  
Emergency exit via the rear window.

### Canopy

Level 1 FOPS (Falling Objects Protective Structure).  
TOPS (Tip-Over Protective Structure).  
ROPS (Roll-Over Protective Structure).  
Vinyl-covered, multi-adjustable, spring-suspended seat.  
Non-slip floor and grab handle for access to the driver's cab.  
Seat belt.  
Working light on the canopy frame.  
Instrumentation and monitoring.

### Cab and canopy versions

Monitoring and warning light for: pre-heating, engine oil pressure, water temperature, battery charging, hydraulic filter restriction, air filter restriction.  
Fuel gauge.  
Hour meter.  
Automatic switching off of engine in the event of overheating or drop in oil pressure.

### Working equipment

EC25 Only - 6'11" (2100 mm) long monoblock boom.  
EC30 Only - 7'7" (2300 mm) long monoblock boom.  
3'11" (1200 mm) dipper.  
140° hydraulic boom offset.  
Boom ram cushion.  
Handling equipment: hook on the bucket with load chart displayed in the driver's cab.  
Remote lubrication of the offset cylinder and the crown gear drive.

### Safety

System for locking the working equipment controls and the travel levers when the left console is raised to access or exit the operator station.  
Engine safety starting: the left console must be raised to operate the starter.  
Pressure accumulator on the power assistance circuit to be able to lower work group to the ground if engine is switched off.  
Key-lockable toolbox.

### Official approval

FOPS 1 conforming to ISO standard 3449 and SAE J1043.  
TOPS conforming to ISO standard 12117.  
ROPS conforming to SAE J1040 and ISO 3471.  
Engine in conformity with US EPA regulations.  
Service and maintenance  
Tool kit.

## OPTIONAL EQUIPMENT

### Working equipment

Long dipper (4'11" - 1500 mm).  
Mechanically-controlled quick-release attachment bracket.  
Hydraulically-controlled quick-release attachment bracket.

### Hydraulic circuits for attachments

Hydraulic circuit for double-acting attachments (Auger, thumb...).  
Hydraulic circuit for operating a clam-shell bucket (opening/closing and rotation of the bucket).

### Undercarriage

Steel tracks (1'0" wide - 300 mm).

### Lighting

Additional working light on the boom.  
Additional rear working light.  
Turning beacon.

### Environmental protection

EC30 Only - Catalytic exhaust.

### Comfort and safety

Radio (cab).  
Anti-theft system (2 programmable codes).  
Rear wind-deflector on canopy.  
Electrical cut-off switch.

### Miscellaneous

Special customized paint (RAL specifications).



Volvo Construction Equipment is different. It's designed, built and supported in a different way. That difference comes from an engineering heritage of over 170 years. A heritage of thinking first about the people who actually use the machines. About how to help them be safer, more comfortable, more productive. About the environment we all share. The result of that thinking is a growing range of machines and a global support network dedicated to helping you do more. People around the world are proud to use Volvo. And we're proud of what makes Volvo different – **More care. Built in.**



*All products are not available in all markets. Under our policy of continuous improvement, we reserve the right to change specifications and design without prior notice. The illustrations do not necessarily show the standard version of the machine.*

# **VOLVO**

**Volvo Construction Equipment  
North America, Inc.**

One Volvo Drive, Asheville, NC 28803-3447

[www.volvoce.com](http://www.volvoce.com)

Ref. No. 22 2 000 9875

Printed in USA  
Volvo, Belley

English

2006.12  
CEX